

Californeon Lighted Pinstriping Application Guidelines 10 Ft. Kit

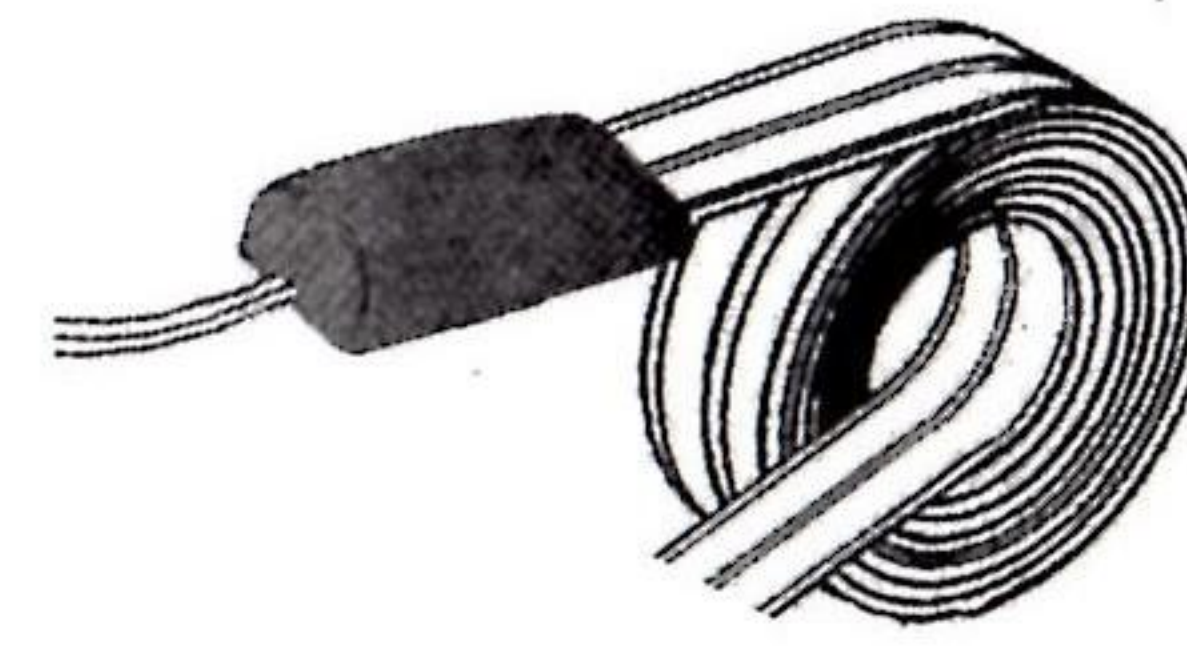

OTHER CAUTIONS:

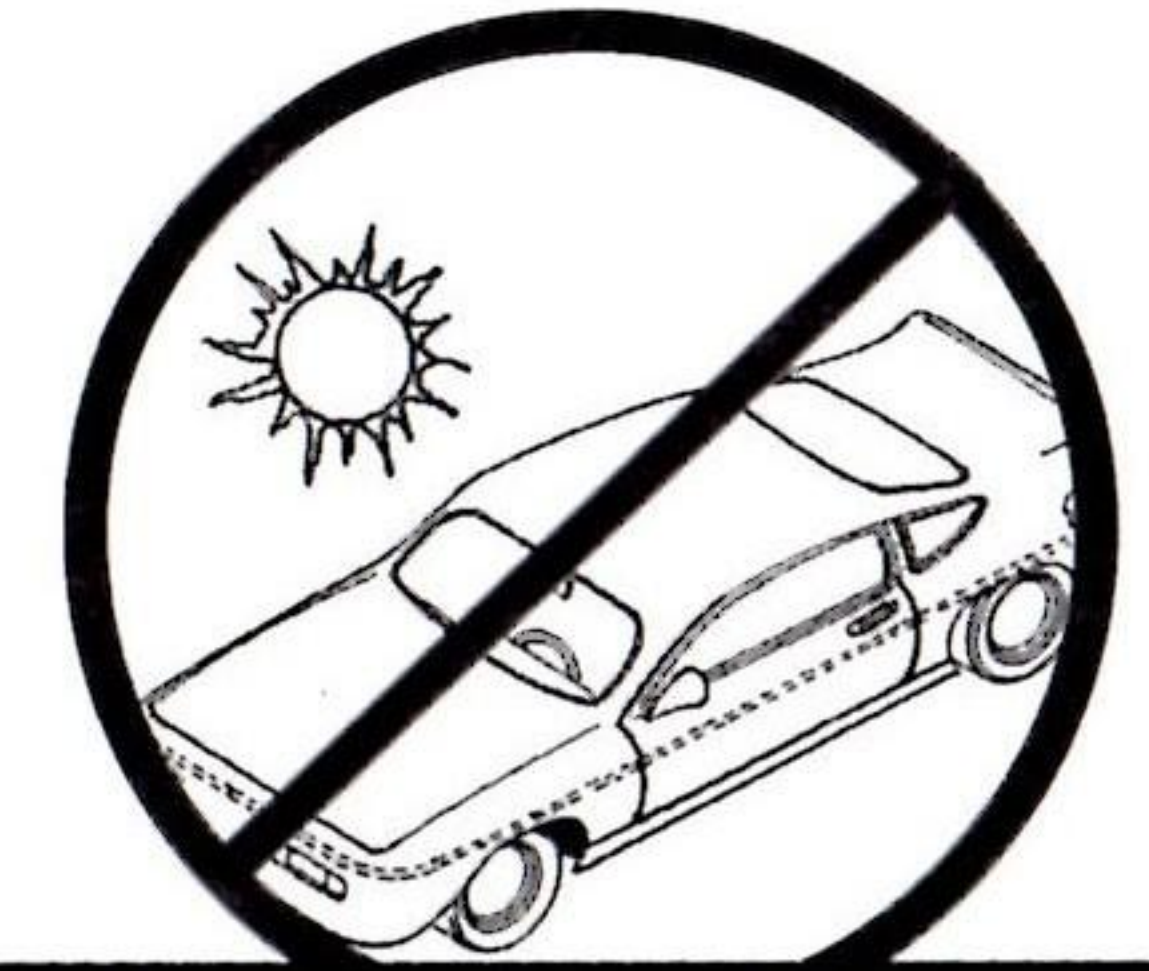

Avoid direct sunlight while applying.



Avoid washing vehicle for first 24 hours.



Do not lay tape on pavement or step on it.

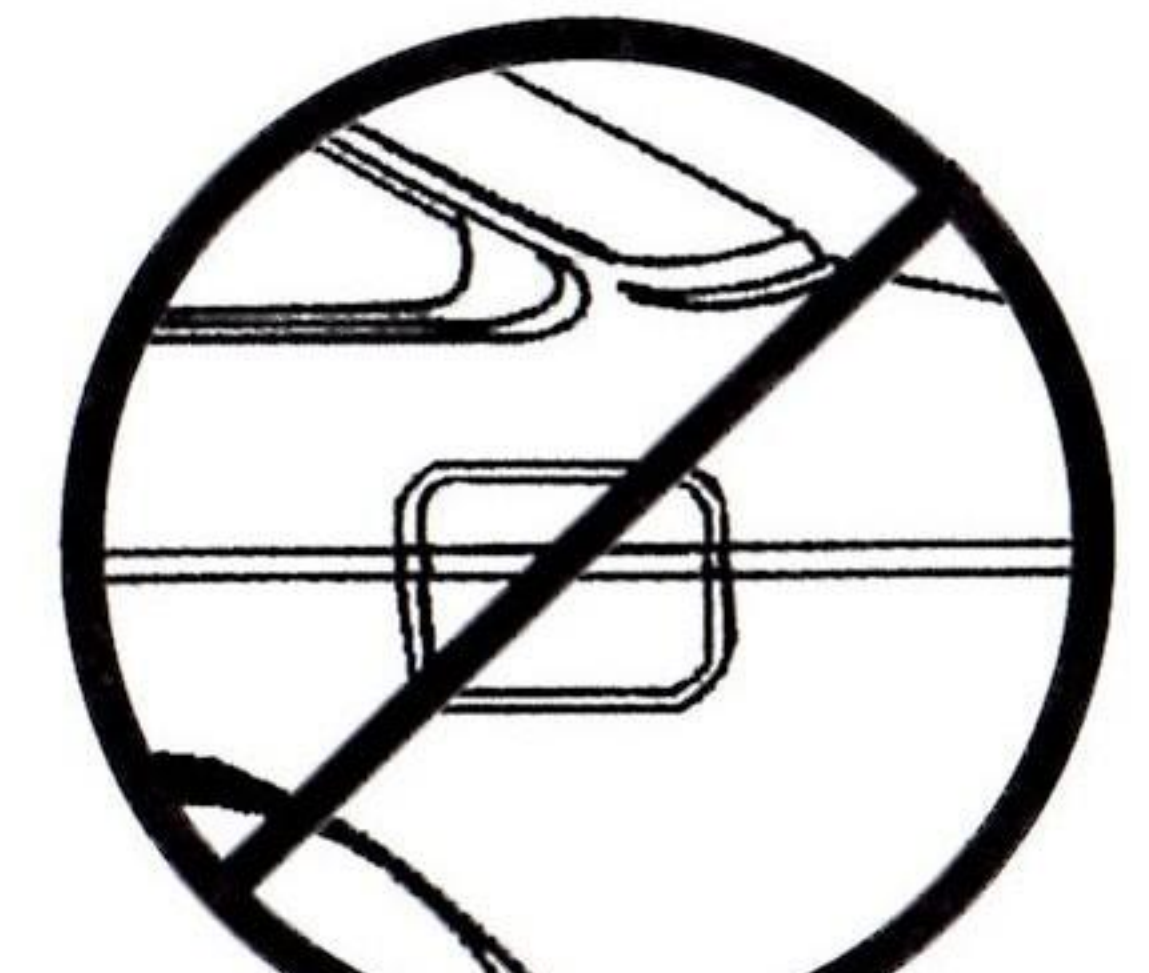

Do not apply on top of or under gas door.

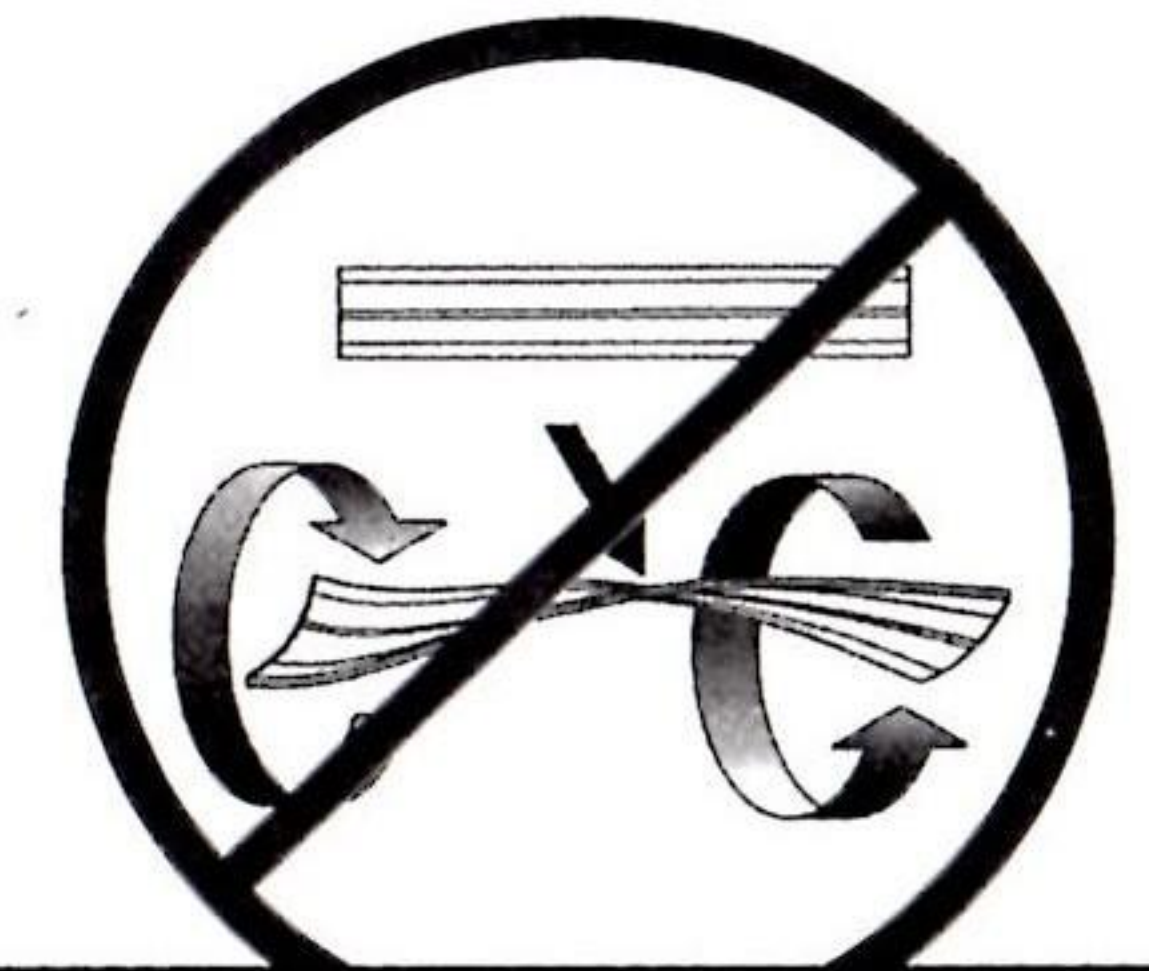

Do not twist.

REVISED 4/00

Introductions & Precautions

Your new Lighted Pinstriping Kit comes pre-connected from the factory. All you have to do is peel off the adhesive backing while applying it to your vehicle. See detailed instructions that follow before proceeding:

CONGRATULATIONS; You have just purchased one of the most exciting lighting products available today. Californeon™ Lighted Pin Striping is a new lighting technology derived from the NASA space program that will provide you years of dramatic lighting enjoyment for your favorite vehicle.

CAUTION; Californeon™ Lighted Pinstriping is a real electric lamp, and is fragile before installation. After it has been installed on your vehicle it is very durable. It is important to protect it from damage both prior to and during installation. Creases and cuts can cause unlit areas to develop, so keep it off the ground so that it does not get stepped on or pick up dirt on its adhesive backing. Do not stretch lamp during installation, this causes dim areas. Lay it down naturally while unwinding from spool. **DO NOT BEND CALIFORNEON** opposite the way it is wound on the spool. This tends to separate the front layer from the back layer resulting in black spots on the lamp when it is lit. Do not pull off or re-position CALIFORNEON after adhesive backing makes contact with vehicle. This may damage the lamp and cause black spots. **BE SURE IT IS** positioned correctly before you apply it to the vehicle! Avoid gasoline and chemical spillage on lamp.

WARNING; Do not hook up power pack without light strip connected. Non-lethal electric shock hazard or product failure may result.

ADDITIONAL TIPS; Read this instruction sheet thoroughly to facilitate easy installation. Wash and dry vehicle thoroughly including door jambs, hood and trunk gutters, and any area where Californeon™ Lighted Pinstriping or wiring is to be applied. For best results, apply in temperatures above 55 degrees (after application, extreme weather is not a hazard).

NEVER use electric buffer on pinstripe. Hand buff with soft terry cloth when waxing or polishing vehicle. Californeon™ is designed for off road and show use. Check local regulations in your state, county, or municipality regarding use of this product for street use. Manufacturer assumes no liability for any improper use or installation.

1 Planning & Measuring

Simply plug in harness ends to make wire connection.

Look at the contours of your vehicle to choose a smooth, flat surface for Californeon™ Lighted Pinstriping. As this is an electrical product, care should be taken to avoid installation where gasoline may be spilled upon it. The best installation area is usually the area below the driver and passenger doors.

1.1. Look over vehicle to determine where to measure, cut, and place Lighted Pinstriping. **NOTE:** Each lamp must be connected to a power supply. Recommended power supply installation areas are engine compartment or tail light housing for trucks and vans.

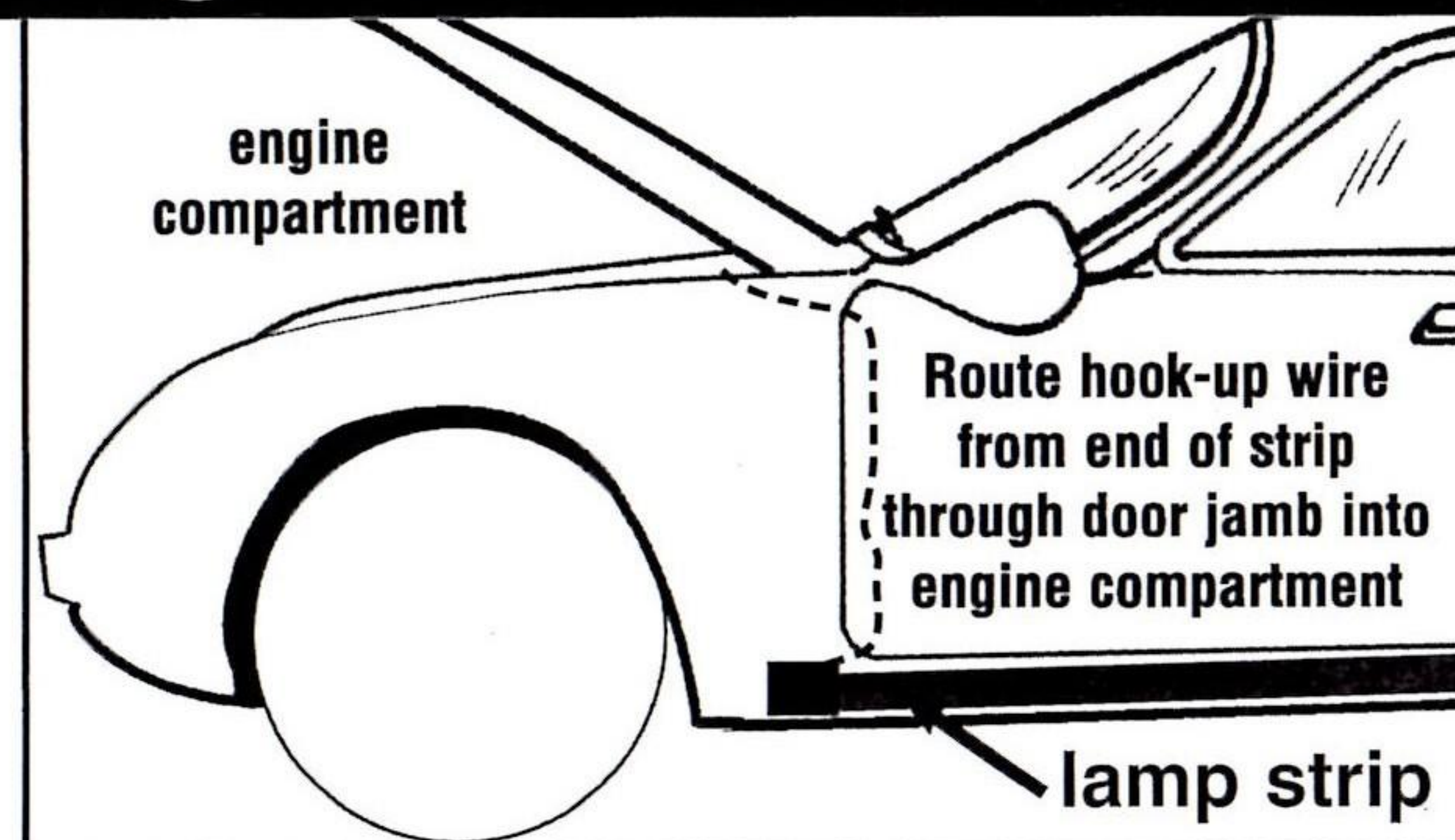

2 Installation Clean all areas with isopropyl alcohol before applying lamp strip

CAUTION: Using small pieces of masking tape, position the E.L. light strips on the vehicle's surface. Do not cut the light strip until you are sure that the layout is correct. Stand back and look from a distance.

2.1 **Before peeling off CALIFORNEON backing.** temporarily apply masking tape to CALIFORNEON using a piece approximately every 10". (See Fig 2.1A) This will hold the CALIFORNEON lamp strips exactly where you want to place them. Now, step back and check your application for good alignment. Next, while pulling off backing paper, **carefully** remove masking tape **one piece at a time** while using your other hand to adhere CALIFORNEON to vehicle. After the Californeon stripe is on the vehicle, slide down the length of the stripe with your thumb to adhere it to the vehicle (this is also important to guard against moisture) **Tightly** bend lamp around final edge, press down to adhere. Care should be taken to ensure straight installation.

CALIFORNEON LIGHTED PINSTRIPING CANNOT BE REPOSITIONED WITHOUT DAMAGE.

2.2 **Routing & Wiring;** Route 6' hook up wire connected to Californeon into area where power supply will be located. Connection will be made by plugging wire from lamp into power supply connector. Hide hook up wire in location where wire connections may not be disturbed.

2.3 Use plastic wire ties included to support and secure electrical lines. Use silicon sealant to protect terminal and connectors when installing connector any place subject to moisture. (Tailgates, inside bumpers, fenders, trunks etc.) **NOTE:** Do this in a dark area. Once all connections have been made it's time to try the Californeon out. **REMEMBER THAT THIS PRODUCT CANNOT BE SEEN IN THE SUNLIGHT** so testing must be done in a dark area. To test, refer to figure 2.1. If the Californeon does not light up immediately, check the connections first. Also listen to the power supply. It should be making a humming sound. Check to see if any wires or wire strands are touching each other causing a short. After checking possible problems listed above feel free to call our hotline if you still have a problem 1 800 323-4329 or 1 805 388-6800.

DIMMER HOOKUP/ACCESSORY NOTES: If you wish to regulate the light intensity of your new CALIFORNEON™ Accent Lighting by means of your instrument panel dimmer control, proceed as follows;

1. Locate a dimmable light in vehicle. Use the Scotch-Lock™ connector to attach the red wire from the power supply to the 12 volt red of the power lead going to the light. Usually, the light behind your cigarette lighter or ash tray is easiest to access.
2. Or, A simple on/off switch (SPST) such as a toggle, rocker, or push button switch can be found at any automotive supply store. Attached in-line on the red wire from the power supply, it can be used to turn the power supply on and off.

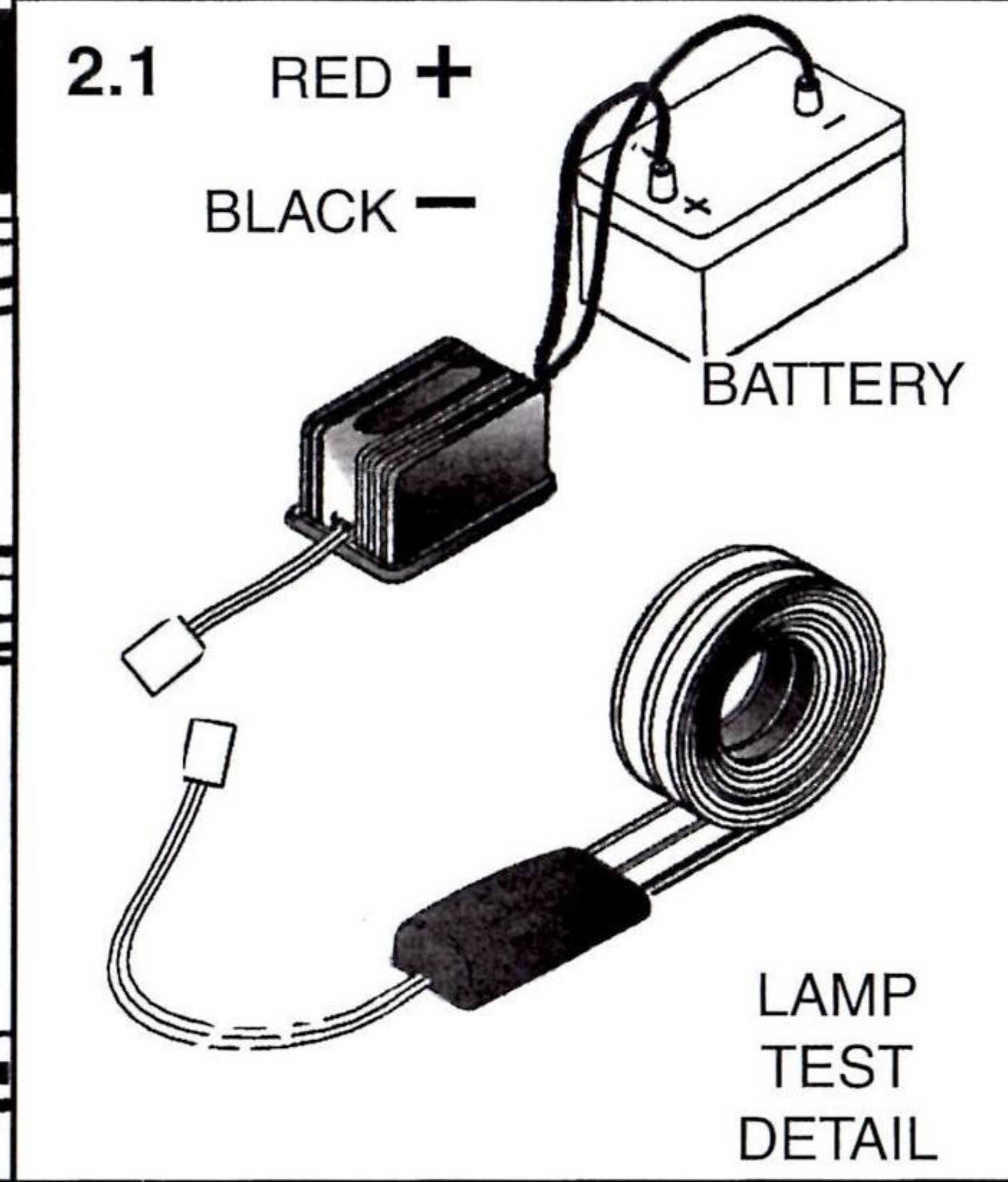
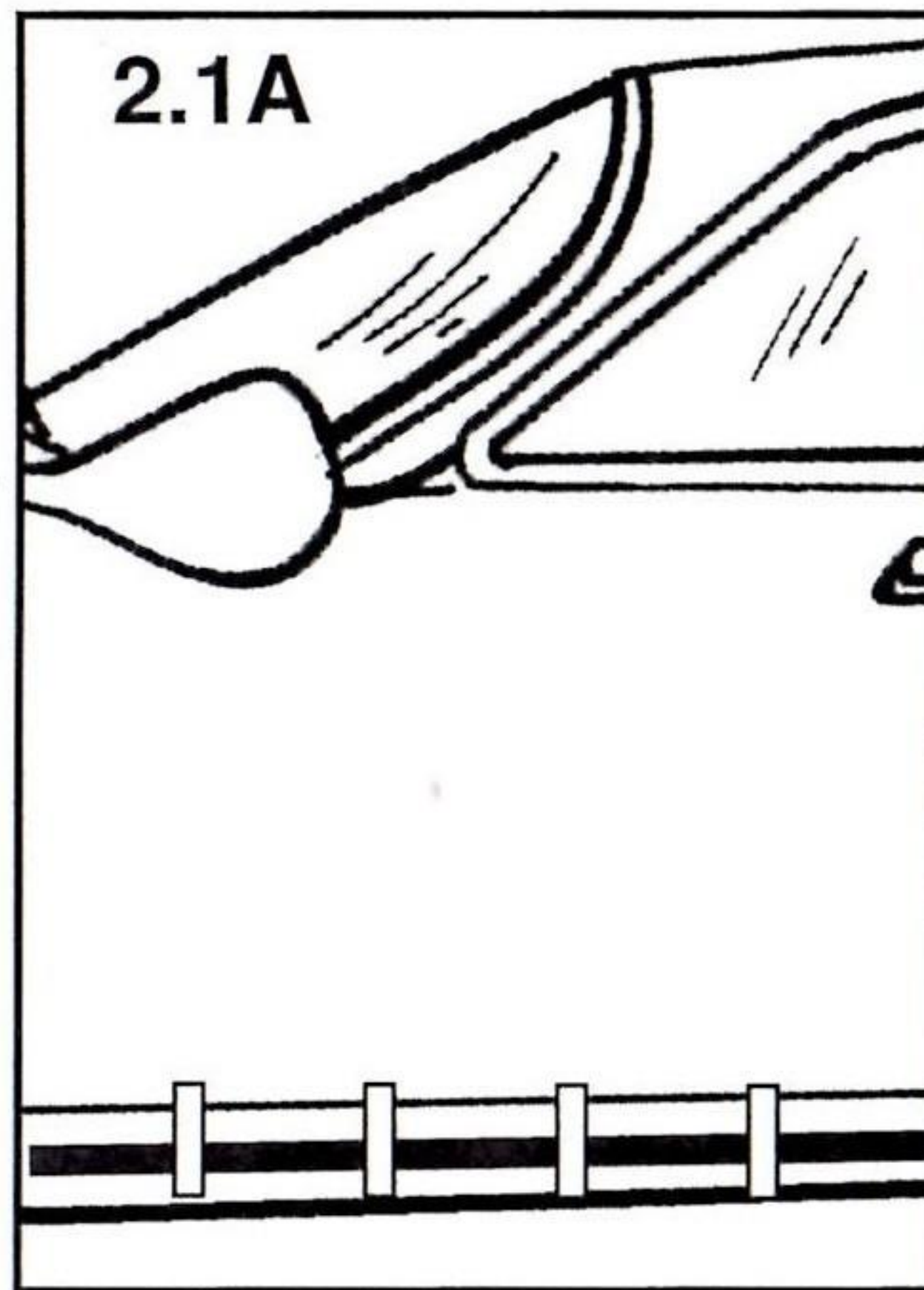

NOTE: Red input wire must be connected only to (+) positive terminals and Black input wire must be connected only to (-) negative terminals on battery or fuse panel. The output wires have no polarity and can be connected to either one of the main harness wires.

CAUTION
Do not hook up Power Pack to 12 volt power until all connections are completed . . . **FAILURE MAY OCCUR!**

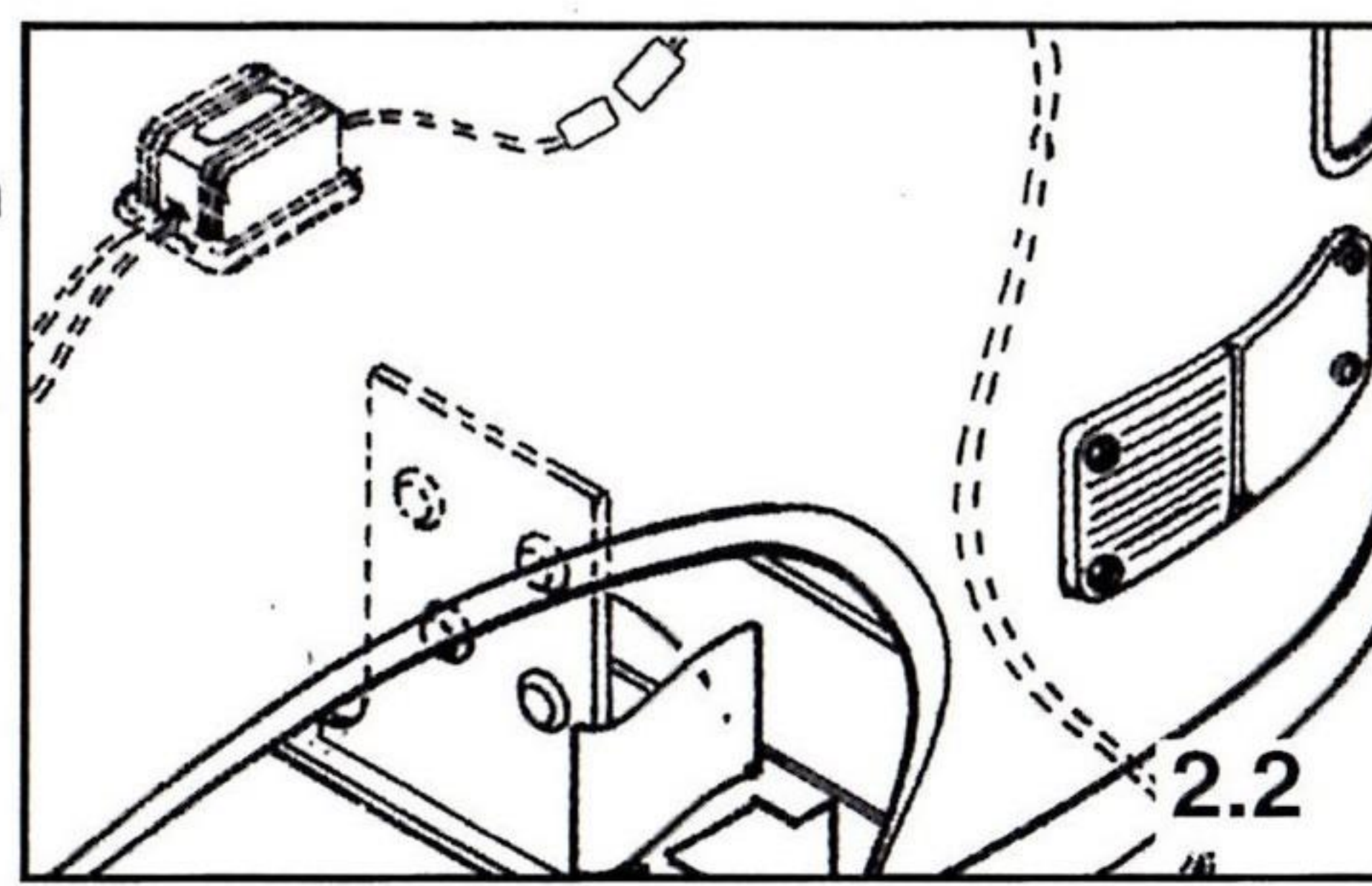
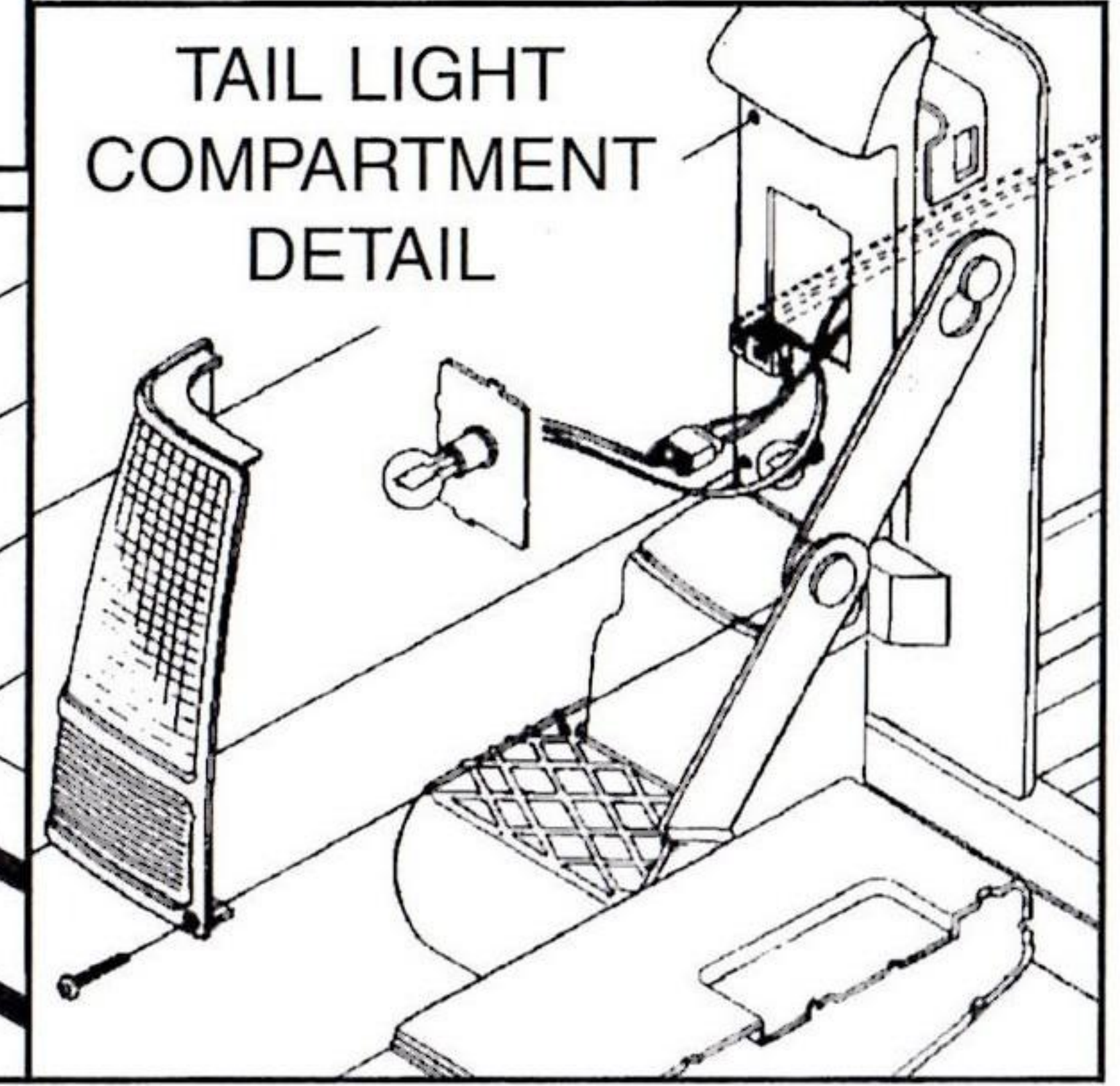
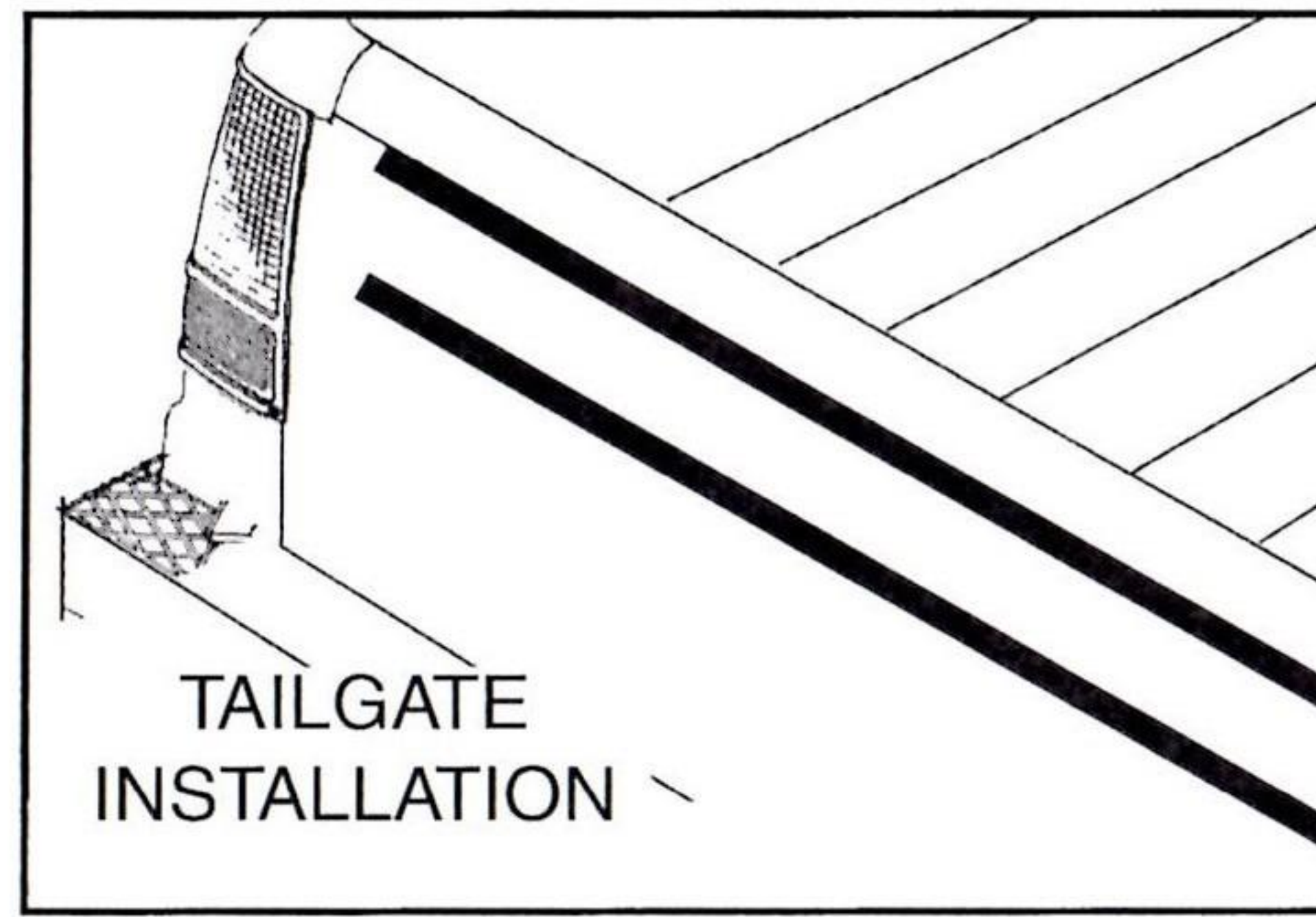

FOR TAILGATE INSTALLATIONS:
Put power supply in rear tail light compartment and use Scotch-Locks (supplied) to tap tail light for power. Tape lamp wires to hidden recesses of tailgate and route to tail light location and plug into the power supply.

